



American
Gear Manufacturers
Association

Technical Resources

10FTM17

AGMA Technical Paper

Self-Locking Gears: Design and Potential Applications

By Dr. A.L. Kapelevich, AKGears,
LLC and Dr. E. Taye, ET
Analytical Engineering, LLC

Self-Locking Gears: Design and Potential Applications

Dr. Alexander L. Kapelevich, AKGears, LLC and Dr. Elias Taye, ET Analytical Engineering, LLC

[The statements and opinions contained herein are those of the author and should not be construed as an official action or opinion of the American Gear Manufacturers Association.]

Abstract

In most of the gear drives, when the driving torque is suddenly reduced as a result of power off, torsional vibration, power outage or any mechanical failure at the transmission input side, then gears will be rotating either in the same direction driven by the system inertia, or in the opposite direction driven by the resistant output load due to gravity, spring load, etc. The latter condition is known as backdriving. During inertial motion or backdriving, the driven output shaft (load) becomes the driving one and the driving input shaft (load) becomes the driven one. There are many gear drive applications where the output shaft driving is less desirable. In order to prevent it, different types of brake or clutch devices are used. However, there are also solutions in gear transmission that prevent inertial motion or backdriving using self-locking gears without any additional devices. The most common one is a worm gear with a low lead angle. In self-locking worm gears, torque applied from the load side (worm gear) is blocked, i.e. cannot drive the worm. However, their application comes with some limitations: the crossed axis shafts' arrangement, relatively high gear ratio, low speed, low gear mesh efficiency, increased heat generation, etc.

The paper describes the design approach as well as potential applications of the parallel axis self-locking gears. These gears, unlike the worm gears don't have such application limitations. They can utilize any gear ratio from 1:1 and higher. They can be external, internal, or incorporated into the planetary gear stage or multistage gear system. Their gear mesh efficiency is significantly higher than the worm gears and closer to conventional gears. As a result they generate less heat. The self-locking can be designed to prevent either the inertia driving, or backdriving, or both. The paper explains the principle of the self-locking process for gears with symmetric and asymmetric teeth profile, and shows their suitability for different applications. It defines the main parameters of gear geometry and operating conditions. It also describes potential self-locking gear applications and references to related publications.

Copyright © 2010

American Gear Manufacturers Association
1001 N. Fairfax Street, Suite 500
Alexandria, Virginia, 22314

October 2010

ISBN: 978-1-55589-992-9

Self-Locking Gears: Design and Potential Applications

Dr. Alexander L. Kapelevich, AKGears, LLC
and Dr. Elias Taye, ET Analytical Engineering, LLC

Introduction

In most gear drives, when driving torque is suddenly reduced as a result of power off, torsional vibration, power outage, or any mechanical failure at the transmission input side, then gears will be rotating either in the same direction driven by the system inertia, or in the opposite direction driven by the resistant output load due to gravity, spring load, etc. The latter condition is known as backdriving. During inertial motion or backdriving, the driven output shaft (load) becomes the driving one and the driving input shaft (load) becomes the driven one. There are many gear drive applications where output shaft driving is undesirable. In order to prevent it, different types of brake or clutch devices are used. However, there are also solutions in the gear transmission that prevent inertial motion or backdriving using self-locking gears without any additional devices. The most common one is a worm gear with a low lead angle. In self-locking worm gears, torque applied from the load side (worm gear) is blocked, i.e. cannot drive the worm. However, their application comes with some limitations: the crossed axis shafts' arrangement, relatively high gear ratio, low speed, low gear mesh efficiency, increased heat generation, etc.

Also there are parallel axis self-locking gears [1, 2]. These gears, unlike the worm gears can utilize any gear ratio from 1:1 and higher. They have the driving mode and self-locking mode, when the inertial or backdriving torque is applied to the output gear. Initially these gears had very low (< 50%) driving efficiency that limited their application. Then it was proved [3] that high driving efficiency of such gears is possible. Criteria of the self-locking was analyzed in this article [4].

This paper explains the principle of the self-locking process for the parallel axis gears with symmetric and asymmetric teeth profile, and shows their suitability for different applications.

Self-locking condition

Figure 1 presents conventional gears (a) and self-locking gears (b), in case of backdriving. Figure 2 presents conventional gears (a) and self-locking gears (b), in case of inertial driving. Practically all conventional gear drives have the pitch point P located in the active portion the contact line B₁-B₂ (Figure 1a and Figure 2a). This pitch point location provides low specific sliding velocities and friction, and, as a result, high driving efficiency. In case when such gears are driven by output load or inertia, they are rotating freely, because the friction moment (or torque) is not sufficient to stop rotation.

In order to make gears self-locking, the pitch point P should be located off the active portion the contact line B₁-B₂. There are two options. Option 1: when the point P is placed between a center of the pinion O₁ and the point B₂, where the outer diameter of the gear intersects the line contact. This makes the self-locking possible, but the driving efficiency will be low under 50% [3]. Option 2 (Figure 1b and Figure 2b): when the point P is placed between the point B₁, where the outer diameter of the pinion intersects the line contact and a center of the gear O₂. This type of gears can be self-locking with relatively high driving efficiency > 50%.

Another condition of self-locking is to have a sufficient friction angle, γ , to deflect the force F' beyond the center of the pinion O₁. It creates the resisting self-locking moment (torque) T'₁ = F' L'₁, L'₁ is a lever of the force F'₁. This condition can be presented as L'_{1min} > 0 or

$$\gamma > \arctan \left[\frac{1}{(1+u) \tan \alpha_w - u \tan \alpha_{a2}} \right] \quad (1)$$

or

$$f > \frac{1}{(1+u) \tan \alpha_w - u \tan \alpha_{a2}} \quad (2)$$

where

$$u \quad \text{is gear ratio,} \\ = \frac{n_2}{n_1}$$

n_2 is number of gear teeth
 n_1 is number of pinion teeth
 α_{a2} is involute profile angle at the tip of the gear tooth

$$= \arccos \frac{d_{b2}}{d_{a2}}$$

Design of self-locking gears

Self-locking gears are custom. They cannot be fabricated with the standards tooling with, for example, the 20° pressure and rack. This makes them very suitable for Direct Gear Design® [5, 6] that provides required gear performance and after that defines tooling parameters

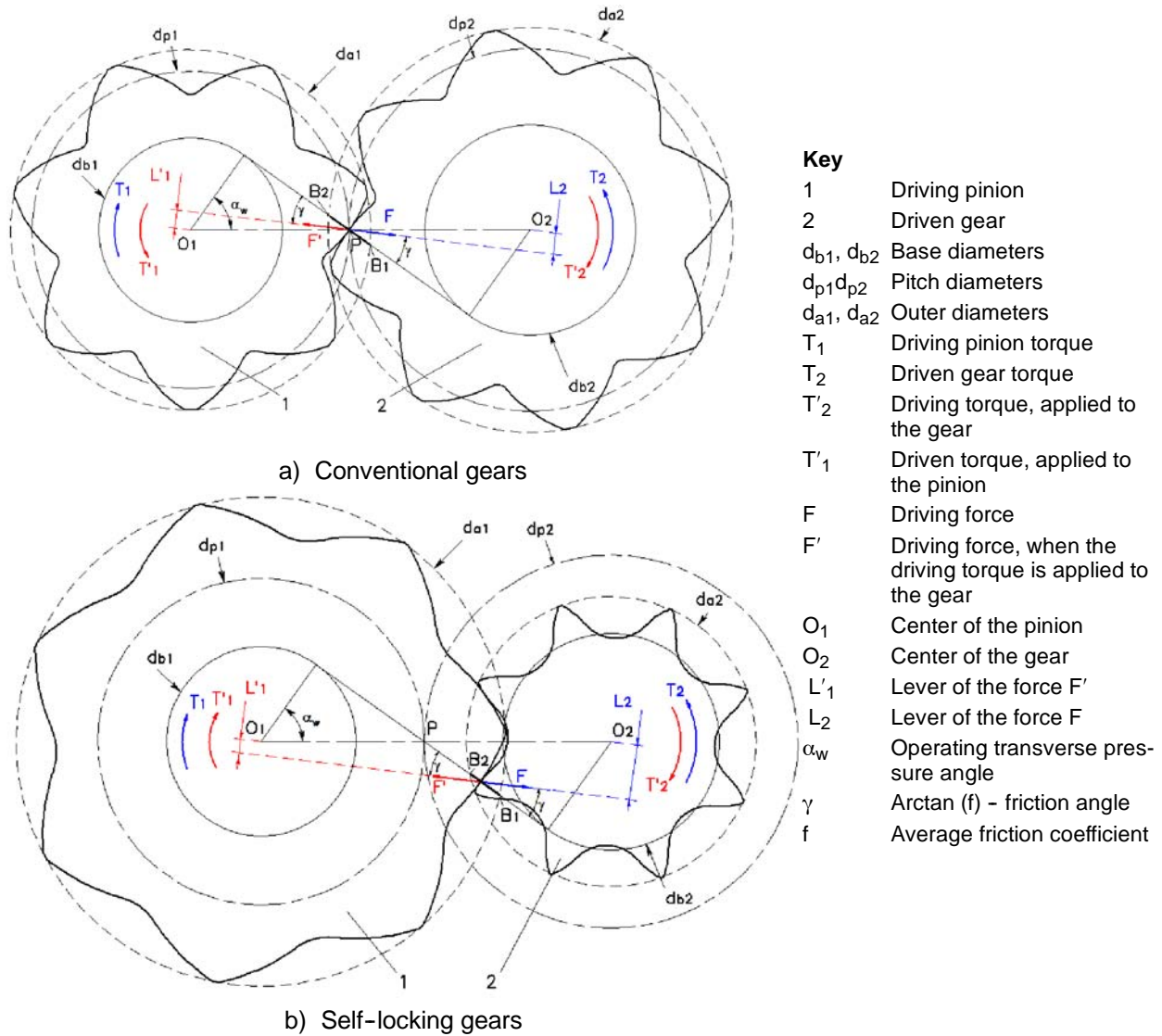

NOTE: Blue shows the normal driving operation, red shows the case when the driven gear becomes the driving by output load.

Figure 1. Conventional (a) and self-locking (b) gears driven by output load

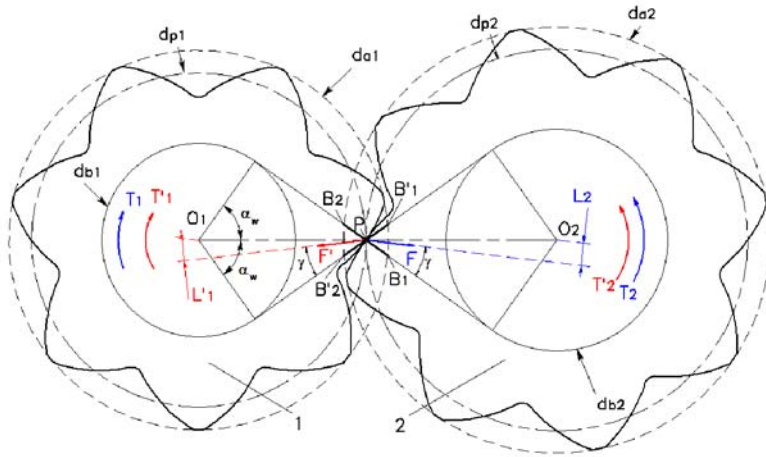

a) Conventional gears

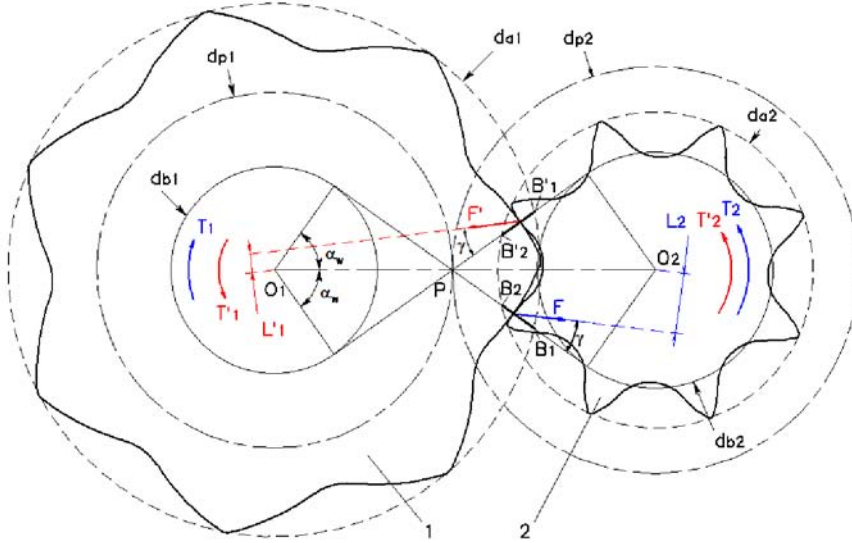

b) Self-locking gears

Key

- 1 Driving pinion
- 2 Driven gear
- d_{b1}, d_{b2} Base diameters
- d_{p1}, d_{p2} Pitch diameters
- d_{a1}, d_{a2} Outer diameters
- T_1 Driving pinion torque
- T_2 Driven gear torque
- T'_2 Driving torque, applied to the gear
- T'_1 Driven torque, applied to the pinion
- F Driving force
- F' Driving force, when the driving torque is applied to the gear
- O_1 Center of the pinion
- O_2 Center of the gear
- L'_1 Lever of the force F'
- L_2 Lever of the force F
- α_w Operating transverse pressure angle
- γ Arctan (f) - friction angle
- f Average friction coefficient

NOTE: Blue shows the normal driving operation, red shows the case when the driven gear becomes the driving by inertia.

Figure 2. Conventional (a) and self-locking (b) gears driven by inertia

Direct Gear Design[®] presents the symmetric gear tooth formed by two involutes of one base circle (Figure 3). The asymmetric gear tooth is formed by two involutes of two different base circles (Figure 3b). The tooth tip circle d_a allows avoiding the pointed tooth tip. The equally spaced teeth form the gear. The fillet profile between teeth is designed independently to avoid interference and provide minimum bending stress.

The operating pressure angle α_w and the contact ratio ϵ_α are defined by the following equations:

for gears with symmetric teeth

$$\text{inv } \alpha_2 = \frac{1}{1+u} \left[\text{inv } v_1 + u \text{inv } v_2 - \frac{\pi}{n_1} \right] \quad (3)$$

$$\epsilon_\alpha = \frac{n_1}{2\pi} \times \left[\tan \alpha_{a1} + u \tan \alpha_{a2} - (1+u) \tan \alpha_w \right] \quad (4)$$

for gears with asymmetric teeth

$$\text{inv } \alpha_{wd} + \text{inv } \alpha_{wc} = \frac{1}{1+u} \times \left[(\text{inv } v_{1d} + \text{inv } v_{1c}) + u (\text{inv } v_{2d} + \text{inv } v_{2c}) - \frac{2\pi}{n_1} \right] \quad (5)$$

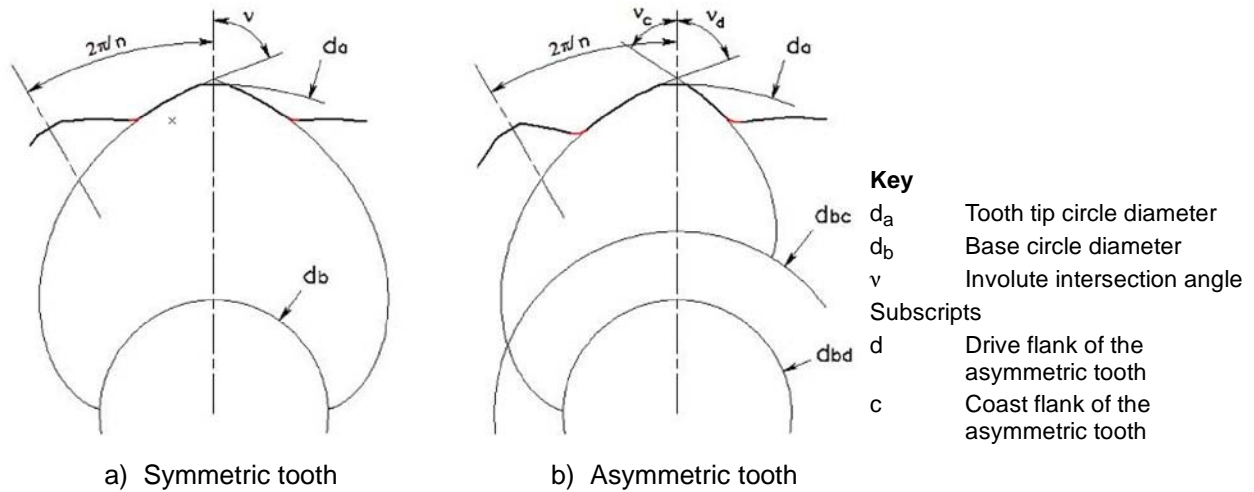

Figure 3. Direct Gear Design® tooth profile definition;

$$\epsilon_{\alpha d} = \frac{n_1}{2\pi} \left[\tan \alpha_{ad1} + u \tan \alpha_{ad2} - (1 + u) \tan \alpha_{wd} \right] \quad (6)$$

$$\epsilon_{\alpha c} = \frac{n_1}{2\pi} \left[\tan \alpha_{ac1} + u \tan \alpha_{ac2} - (1 + u) \tan \alpha_{wc} \right] \quad (7)$$

where

$\text{inv}(x)$ is involute function of the profile angle x
(in radians)
 $= \tan x - x$

Conditions (1) and (2) show that self-locking requires high pressure and high sliding friction in the

tooth contact. If the sliding friction coefficient $f = 0.1 - 0.3$, it requires the transverse operating pressure angle to $\alpha_w = 75 - 85^\circ$. As a result, the transverse contact ratio $\epsilon_\alpha < 1.0$ (typically $0.4 - 0.6$). Lack of the transverse contact ratio should be compensated by the axial (or face) contact ratio ϵ_β to guarantee the total contact ratio $\epsilon_\gamma = \epsilon_\alpha + \epsilon_\beta \geq 1.0$. This can be achieved by using helical gears (Figure 4a). However, helical gears apply the axial (thrust) force on the gear bearings. The double helical (or “herringbone”) gears (Figure 4b) allow to compensate this force.

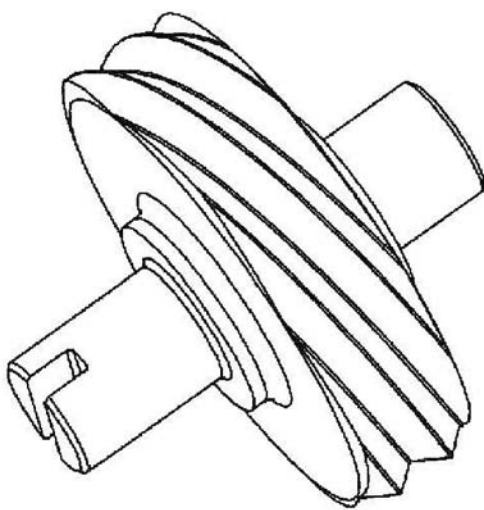

a) Helical gear

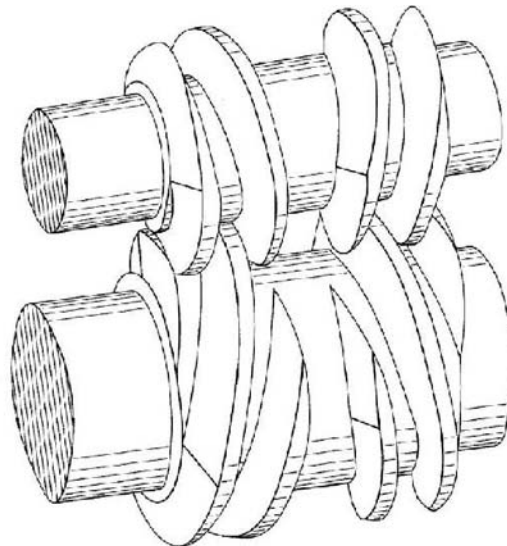

b) Double helical gears

Figure 4. Self-locking gear design

High transverse pressure angles result in increased bearing radial load that could be up to 4–5 times higher than for the conventional 20° pressure angle gears. Bearing selection and gearbox housing design should be done accordingly to hold this increased load without excessive deflection.

Application of the asymmetric teeth for unidirectional drives allows for improved performance. For the self-locking gears that are used to prevent backdriving, the same tooth flank is used for both driving and locking modes. In this case, asymmetric tooth profiles provide much higher transverse contact ratio at the given pressure angle than the symmetric tooth flanks. It makes it possible to reduce the helix angle and axial bearing load. For the self-locking gears that used to prevent inertial driving, different tooth flanks are used for driving and locking modes. In this case, asymmetric tooth profile with low-pressure angle provides high efficiency for driving mode and the opposite high-pressure angle tooth profile is used for reliable self-locking.

Testing of self-locking gears

Self-locking helical gear prototype sets were made based on the developed mathematical models. The gear data are presented in the Table 1. The test gears are presented in Figure 5.

The schematic presentation of the test setup is shown in Figure 6. The 0.5 Nm electric motor was

used to drive the actuator. An integrated speed and torque sensor was mounted on the high-speed shaft of the gearbox and Hysteresis Brake Dynamometer (HD) was connected to the low speed shaft of the gearbox via coupling. The input and output torque and speed information were captured in the data acquisition tool and further analyzed in a computer using data analysis software. The instantaneous efficiency of the actuator was calculated and plotted for a wide range of speed/torque combination. Average driving efficiency of the self-locking gear obtained during testing was above 85%. The self-locking property of the helical gear set in backdriving mode was also tested. During this test the external torque was applied to the output gear shaft and the angular transducer showed no angular movement of input shaft, which confirmed the self-locking condition.

Table 1. Testing of self-locking gears

Gear	Input	Output
Number of teeth	6	11
Normal module, mm	1.500	
Normal pressure angle	63°	
Helix angle on the pitch diameter	75°	
Transverse pressure angle	82.5°	
Transverse contact ratio	0.50	
Axial contact ratio	2.00	

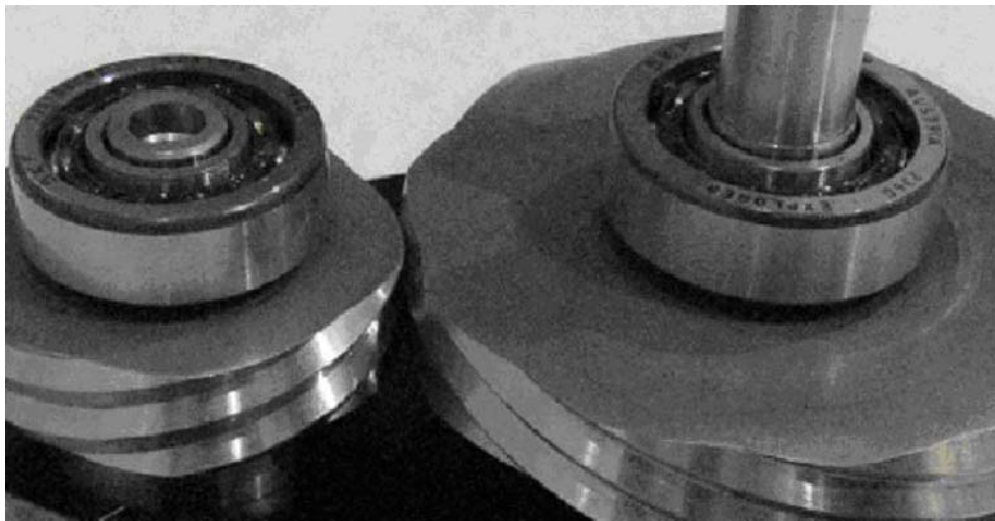

Figure 5. Helical self-locking test gears

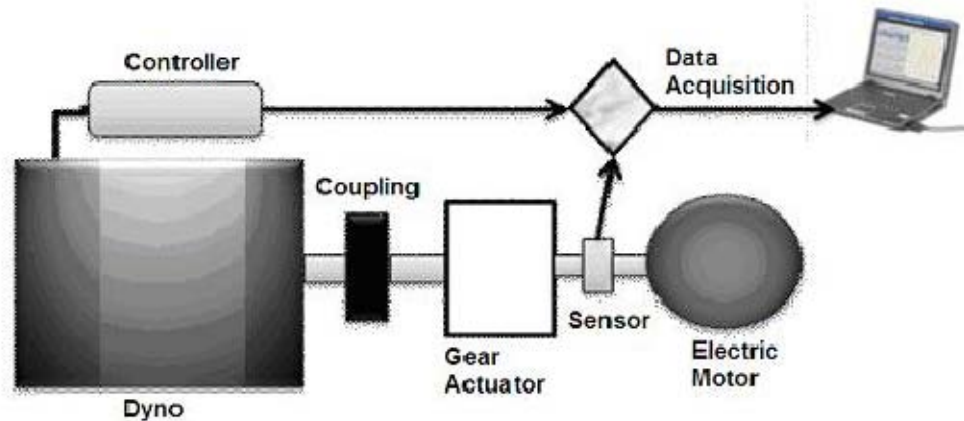

Figure 6. Helical self-locking gear actuator test bench

Potential applications

Initially self-locking gears were used in textile industry [2]. However, this type of gears has many potential applications in lifting mechanisms, assembly tooling, and other gear drives where the backdriving or inertial driving is not permissible. One of such application [7] of the self-locking gears for a continuously variable valve lift system was suggested for an automotive engine.

Summary

- A principle of work of the self-locking gears is described.
- Design specifics of the self-locking gears with symmetric and asymmetric profiles are shown.
- Testing of the gear prototypes has proved relatively high driving efficiency and reliable self-locking.
- The self-locking gears may find many applications in various industries. For example, in a control systems where position stability is very important (such as in automotive, aerospace, medical, robotic, agricultural etc.) the self-locking will allow to achieve required performance.
- Similar to the worm self-locking gears, the parallel axis self-locking gears are sensitive to operating conditions. The locking reliability is affected by lubrication, vibration, misalignment, etc.

- Implementation of these gears should be done with caution and requires comprehensive testing in all possible operating conditions.

References

1. Popper ,J.B., *Cooperating Wedges including mating worms*, US Patent 2973660, 1961
2. Munster, N.S., Tzarev, G.V., *Self-locking Cylindrical Gears, Theory Mechanisms and Machines*, Publications of the Tashkent Polytechnic Institute, 1968, #30A, 3 – 15 (in Russian)
3. Iskhakov, T.G., *Self-locking in Gear Mechanisms*, Publications of the Kazan Aviation Institute, 1969, #105, Vol. 105, 3 – 15 (in Russian)
4. Timofeev, G.A., Panukhin, V.V., *Self-locking Criteria Analysis*, Vestnik Mashinostroenia, September 2003, 3 – 8 (in Russian)
5. Kapelevich, A.L., Kleiss, R.E., *Direct Gear Design for Spur and Helical Gears*, Gear Technology, September/October 2002, 29 – 35
6. Kapelevich, A.L., *Geometry and design of involute spur gears with asymmetric teeth*, Mechanism and Machine Theory, 2000, Issue 35, pp. 117-130
7. Taye, E., *Actuator with self-locking helical gears for a continuously variable valve lift system*, US Patent #US2009/0283062 A1 (pending)